

This document describes modifications to a Logitech Wingman Formula Force wiring harness to permit use of Act Labs Performance Pedals with the LWFF as a "single USB game controller" in Windows (for sims which do NOT support multiple controllers, i.e., Colin McRae Rally 2/3, Sports Car GT, Mobil Rally Championship)

Original Logitech USB adapter & plug

NEW wiring harness from Logitech harness to "breakout box"

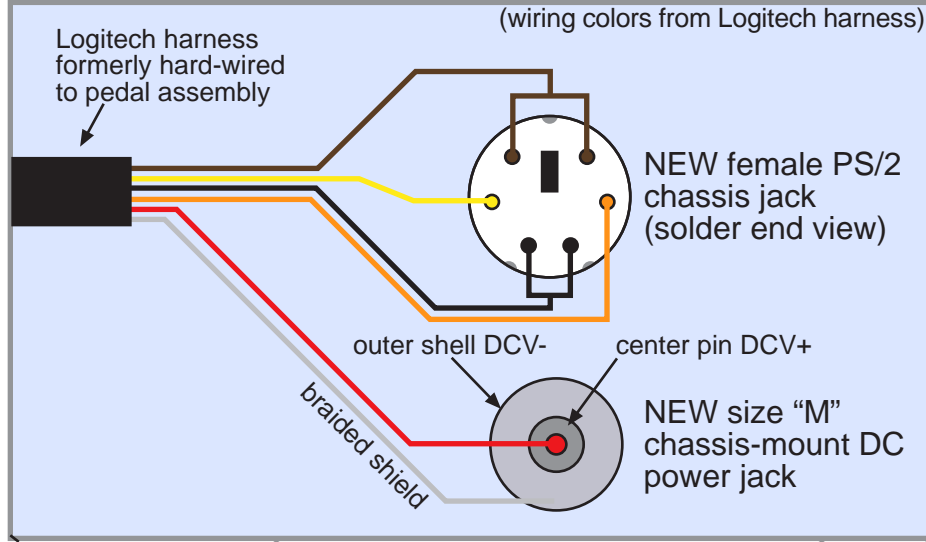

This end of the original Logitech harness was formerly hard-wired inside the stock pedal assembly.

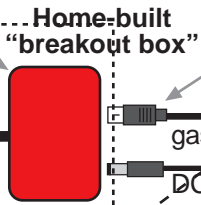

Former Logitech harness path

NEW wiring harness from original pedals to PS/2 plug

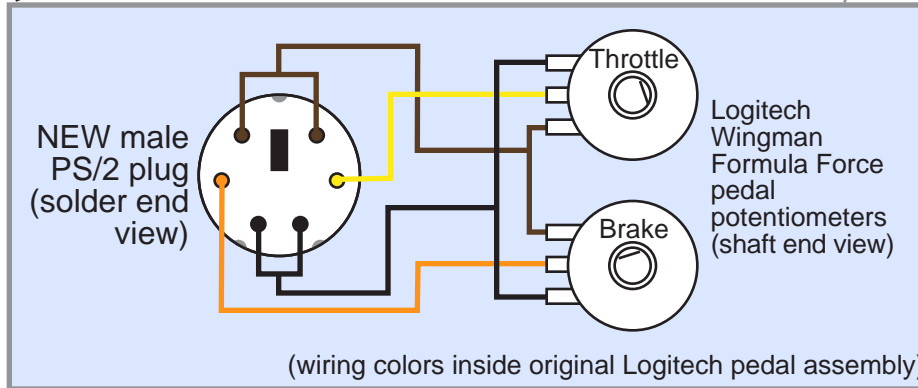

Parts in red are fabricated for the modification

When the breakout box is used, only the Clutch Cable is plugged into the Act Labs USB adapter, and the clutch is the only 2nd USB controller axis.

Act Labs Pedal assembly and harness is **unmodified**. The gas/brake cable can be plugged into either the Logitech harness or the Act Labs USB adapter

This new cable with a PS/2 plug permits the restoration of the original Logitech pedals, and is **not** necessary if you intend to abandon the Logitech pedals

A new DC power jack which drives the force feedback in the wheel is permanently relocated from the pedal base to a home-built "breakout box."

